

# Model AHU-L SQ 30

## TECHNICAL DATA

Model		TYPE A
Air Flow (at high speed) <sup>1</sup>	m <sup>3</sup> /h	5100
	cfm	3000
Fan Type And Model		2x Centrifugal 10"x10"
High Fan Speed	R.P.M	800
Number of Speeds		3
Noise Level – H / M / L <sup>2</sup>	dBa	41 / 36 / 32
Power Supply	V/Ph/Hz	230V, 1Ph, 50Hz
Current Consumption	Amp	5.2
Weight	kg	110
Coil Face Area	m <sup>2</sup>	0.65
Fins Spacing	Per Inch	12 for 4-row coil, 10 for 6-row coil

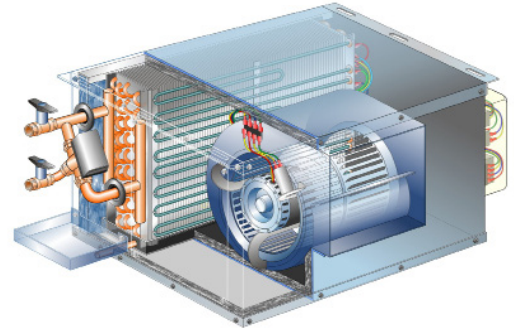

NOTES: 1. Air Flow refers to 4 row coil and 6 mm H<sub>2</sub>O external pressure drop.  
 2. Noise level refers to a ducted unit at a distance of 1.5m from the unit.

### HORIZONTAL UNIT

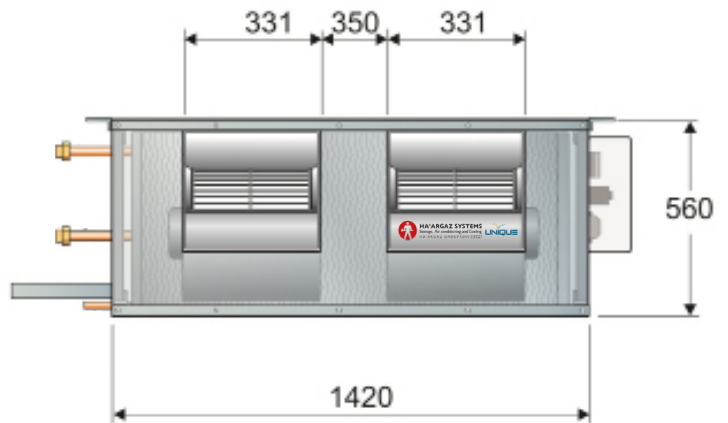
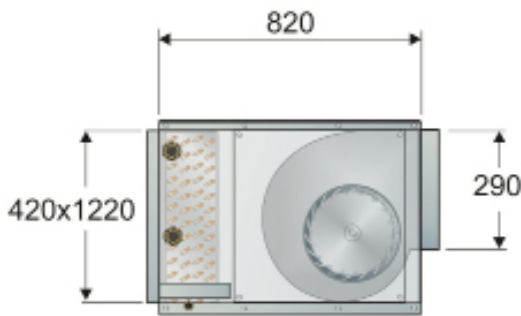



## PERFORMANCE

<b>COOLING CAPACITY FOR 4 ROW COIL</b>																	
<b>AIR Entering Temperature</b>		<b>22.8°C DB 16.7°C WB</b>				<b>25°C DB 18.3°C WB</b>				<b>26.7°C DB 19.4°C WB</b>				<b>29.4°C DB 21.7°C WB</b>			
<b>EWT °C</b>	<b>WTR °C</b>	<b>CAP Watt</b>	<b>CAP Btu/h</b>	<b>WF m³/h</b>	<b>PD m H<sub>2</sub>O</b>	<b>CAP Watt</b>	<b>CAP Btu/h</b>	<b>WF m³/h</b>	<b>PD m H<sub>2</sub>O</b>	<b>CAP Watt</b>	<b>CAP Btu/h</b>	<b>WF m³/h</b>	<b>PD m H<sub>2</sub>O</b>	<b>CAP Watt</b>	<b>CAP Btu/h</b>	<b>WF m³/h</b>	<b>PD m H<sub>2</sub>O</b>
5.5	4.4	23154	79002	4.5	1.6	27530	93933	5.3	2.0	30632	104517	5.9	2.2	37223	127008	7.2	2.9
	5.5	22051	75240	3.4	1.2	26219	89460	4.1	1.5	29173	99540	4.5	1.6	35451	120960	5.5	2.1
	6.7	20949	71478	2.7	1.0	24908	84987	3.2	1.1	27714	94563	3.6	1.3	33678	114912	4.4	1.6
7.2	4.4	20218	68985	3.9	1.3	24372	83160	4.7	1.7	27696	94500	5.4	2.0	34287	116991	6.6	2.7
	5.5	19255	65700	3.0	1.0	23212	79200	3.6	1.3	26377	90000	4.1	1.5	32655	111420	5.1	1.9
	6.7	18292	62415	2.4	0.8	22051	75240	2.8	1.0	25058	85500	3.2	1.1	31022	105849	4.0	1.4
8.9	4.4	17116	58401	3.3	0.8	21520	73427	4.2	1.5	24594	83916	4.8	1.7	31213	106502	6.0	2.3
	5.5	16301	55620	2.5	0.9	20495	69930	3.2	1.1	23423	79920	3.6	1.3	29727	101430	4.6	1.7
	6.7	15486	52839	2	0.8	19470	66434	2.5	0.9	22252	75924	2.9	1.0	28241	96359	3.7	1.3

<b>COOLING CAPACITY FOR 6 ROW COIL</b>																	
<b>AIR Entering Temperature</b>		<b>22.8°C DB 16.7°C WB</b>				<b>25°C DB 18.3°C WB</b>				<b>26.7°C DB 19.4°C WB</b>				<b>29.4°C DB 21.7°C WB</b>			
<b>EWT °C</b>	<b>WTR °C</b>	<b>CAP Watt</b>	<b>CAP Btu/h</b>	<b>WF m³/h</b>	<b>PD m H<sub>2</sub>O</b>	<b>CAP Watt</b>	<b>CAP Btu/h</b>	<b>WF m³/h</b>	<b>PD m H<sub>2</sub>O</b>	<b>CAP Watt</b>	<b>CAP Btu/h</b>	<b>WF m³/h</b>	<b>PD m H<sub>2</sub>O</b>	<b>CAP Watt</b>	<b>CAP Btu/h</b>	<b>WF m³/h</b>	<b>PD m H<sub>2</sub>O</b>
5.5	4.4	26755	91291	5.2	1.3	31812	108545	6.2	1.6	35396	120775	6.9	1.8	43013	146765	8.3	2.4
	5.5	25481	86944	3.9	1.0	30297	103376	4.7	1.2	33711	115024	5.2	1.3	40965	139776	6.4	1.7
	6.7	24207	82597	3.1	0.8	28782	98207	3.7	0.9	32025	109273	4.1	1.1	38917	132787	5.0	1.3
7.2	4.4	23365	79716	4.5	1.2	28164	96096	5.5	1.4	32004	109200	6.2	1.6	39621	135190	7.7	2.1
	5.5	22250	75920	3.5	0.9	26822	91520	4.2	1.1	30480	104000	4.7	1.3	37734	128752	5.9	1.5
	6.7	21138	72214	2.7	0.8	25481	86944	3.3	0.9	28956	98800	3.8	1.0	35848	122314	4.6	1.2
8.9	4.4	19778	67846	3.8	0.7	24867	84848	4.8	1.3	28420	96970	5.5	1.4	36069	123068	7.0	1.9
	5.5	18837	64272	2.9	0.8	23683	80808	3.7	0.9	27066	92352	4.1	1.1	34351	117208	5.3	1.3
	6.7	17895	61058	2.3	0.7	22499	76768	2.9	0.8	25713	87734	3.3	0.9	32633	111348	4.2	1.1

<b>HEATING CAPACITY</b>													
		<b>4 Row Coil</b>				<b>1 Row Coil</b>				<b>2 Row Coil</b>			
<b>AIR Entering Temperature</b>		<b>21 °C</b>				<b>21 °C</b>				<b>21 °C</b>			
<b>EWT °C</b>	<b>WTD °C</b>	<b>CAP Watt</b>	<b>CAP Btu/h</b>	<b>WF m³/h</b>	<b>PD m H<sub>2</sub>O</b>	<b>CAP Watt</b>	<b>CAP Btu/h</b>	<b>WF m³/h</b>	<b>PD m H<sub>2</sub>O</b>	<b>CAP Watt</b>	<b>CAP Btu/h</b>	<b>WF m³/h</b>	<b>PD m H<sub>2</sub>O</b>
45	5	25472	86910	4.0	1.4								
70	20					19766	67440	1.3	1.1	35725	121895	2.3	2.4

EWT - Entering Water Temp. | WTR - Water Temp. Rise | WTD - Water Temp. Drop | CAP-Cooling/Heating Capacity | PD - Water Pressure Drop | WF - Water Flow Rate

